

# ŠIROKOROZSAHOVÉ NÝTY

## Série 1691 + 1661 + 1001



**HLINÍK**  
AIMg 2,5



**OCEL**  
POZINKOVÁNO

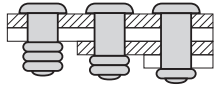
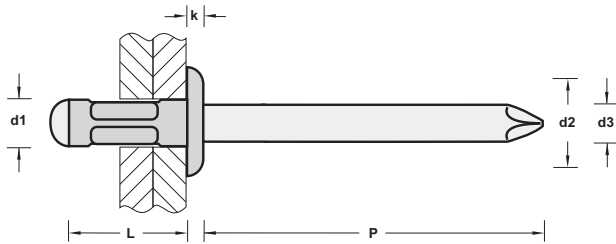

Všechny rozměry v mm.

d1 Ø	Ø : 3.1 - 3.3
d2 Ø	: 6.0 [+/-0.24]
k	: ≤1.4
P	: ≥27
d3	: ~1.7
	⊕ : 655 N
	⊖ : 520 N

Všechny rozměry v mm.

d1 Ø	Ø : 3.3 - 3.4
d2 Ø	: 6.0 - 6.7
k	: ≤1.1
P	: ≥31
d3	: ~1.75
	⊕ : 980 N
	⊖ : 680 N

	L [+1/-0.2]	Objednáací číslo	
	0.5- 3.0	6.0	10013006
	0.8- 4.3	6.7	16915307
	0.5- 5.0	8.0	10013008
	2.5- 7.0	10.0	10013010
	4.5- 9.0	12.0	10013012

	0.5- 3.0	6.0	10013206
	0.8- 4.8	7.9	16910410
	0.5- 5.0	8.0	10013208
	2.0- 6.5	9.5	10013209
	1.2- 6.3	9.6	16610412
	2.5- 7.0	10.0	10013210
	3.5- 8.0	11.1	10013211
	4.0- 7.9	11.2	16910414
	4.5- 9.0	12.0	10013212
	5.5- 9.5	13.5	16610416
	6.5-11.0	14.0	10013214
	8.5-13.0	16.0	10013216

Všechny rozměry v mm.

d1 Ø	Ø : 4.1 - 4.3
d2 Ø	: 8.0 - 8.2
k	: ≤1.7
P	: ≥2.0
d3	: ~2.18
	⊕ : 1600 N
	⊖ : 1100 N

+0.08  
-0.15

Všechny rozměry v mm.

d1 Ø	Ø : 4.9 - 5.2
d2 Ø	: 9.5 - 10.1
k	: ≤2.0
P	: ≥30
d3	: ~2.8
	⊕ : 2300 N
	⊖ : 1300 N

+0.08  
-0.15

Všechny rozměry v mm.

d1 Ø	Ø : 6.6 - 6.9
d2 Ø	: 13.5
k	: ≤2.7
P	:
d3	: 4.0
	⊕ : 3100 N
	⊖ : 2500 N

+0.08  
-0.15

	L [+1/-0.2]	Objednáací číslo	
	0.5- 2.5	6.0	10010406
	0.5- 3.2	6.3	16910508
	0.8- 4.7	7.9	16910510
	0.5- 4.5	8.0	10014008
	1.0- 6.0	9.5	10014009
	1.2- 6.3	9.5	16910512
	1.5- 6.5	10.0	10014010
	3.5- 8.5	12.0	10014012
	4.0- 9.6	12.7	16910516
	5.5-10.5	14.0	10014014
	7.5-12.5	16.0	10014016
	6.4-12.7	16.7	16910521
	8.5-13.5	17.0	10014017
	9.5-14.5	18.0	10014018
	11.5-16.5	20.0	10014020

	0.5- 5.0	10.0	10014810
	0.5- 5.5	10.3	10014811
	1.6- 6.3	10.3	16910613
	2.0- 7.0	12.0	10014812
	4.0- 9.0	14.0	10014814
	4.8-11.1	15.1	16910619
	6.0-11.0	16.0	10014816
	6.4-12.7	16.7	16910621
	7.0-12.0	17.0	10014817
	8.0-13.0	18.0	10014818
	10.0-15.0	20.0	10014820
	12.0-17.0	22.0	10014822
	14.0-19.0	24.0	10014824
	12.7-19.8	24.0	16910631
	14.5-19.5	24.8	10014825
	17.0-23.0	27.0	10014827
	20.0-25.0	30.0	10014830

	1.5- 8.3	16.8	16104506
--	----------	------	----------

## Série 1624 + 1461



**OCEL**  
POZINKOVÁNO



**OCEL**  
POZINKOVÁNO

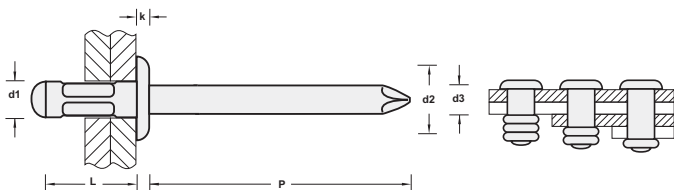

Všechny rozměry v mm.

d1 Ø	Ø : 3.3 - 3.4
d2 Ø	: 7.2
k	: 0.9
P	: ≥27
d3	: ≈2.1
	⊕ : 1710 N
	⊖ : 1335 N

11

	L [+1/-0.2]	Objednáací číslo	
	1.1- 4.0	9.5	16240411

Všechny rozměry v mm.

d1 Ø	Ø : 4.1 - 4.2
d2 Ø	: 8.1
k	: 1.2
P	: ≥30
d3	: ≈2.8
	⊕ : 2355 N
	⊖ : 1955 N

Všechny rozměry v mm.

d1 Ø	Ø : 4.9 - 5.0
d2 Ø	: 9.8
k	: 1.8
P	: ≥30
d3	: ≈3.4
	⊕ : 3470 N
	⊖ : 3335 N (dle délky nýtu)

	L [+1/-0.2]	Objednáací číslo	
	1.4- 5.0	10.8	16240514
	1.5- 4.5	10.8	14614010
	3.0- 6.0	12.5	14614012

	1.2- 4.8	10.2	16240612
	4.0- 6.3	12.7	16240616
	3.5- 7.5	12.0	14614812
	8.0-12.0	17.5	14614817

# Série 1171

**HLINÍK**  
AlMg 2,5

**OCEL**  
POZINKOVÁNO

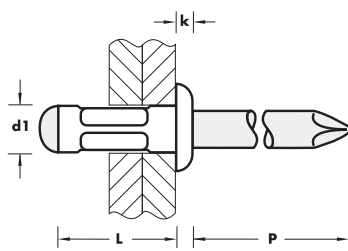

## BÍLÝ LAK RAL 9010

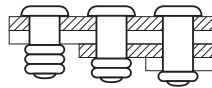

Všechny rozměry v mm.

<b>d1 Ø</b>	Ø $\text{---}$ : 3.1 [3.3 max]
<b>d2 Ø</b>	: 6.0 [+/-0.24]
<b>k</b>	: ≤1.4
<b>P</b>	: ≥27
<b>d3</b>	: 1.7
	⊕ : 654 N
	⊖ : 522 N

Všechny rozměry v mm.

<b>d1 Ø</b>	Ø $\text{---}$ : 3.3 [3.5 max]
<b>d2 Ø</b>	: 6.0 [+/-0.24]
<b>k</b>	: ≤1.4
<b>P</b>	: ≥27
<b>d3</b>	: 1.78
	⊕ : 980 N
	⊖ : 680 N

	L [+1/-0.2]		Objednáací číslo
	1.0- 4.0	6.0	11713006
	1.0- 5.5	8.0	11713008
	2.5- 7.0	10.0	11713010
	4.5- 9.0	12.0	11713012

	L [+1/-0.2]		Objednáací číslo
	0.5- 3.0	6.0	11713206
	0.5- 5.0	8.0	11713208
	2.0- 6.5	9.5	11713209
	2.5- 7.0	10.0	11713210
	3.5- 8.0	11.1	11713211
	4.5- 9.0	12.0	11713212
	5.5- 9.5	12.7	11713213
	6.5-11.0	14.0	11713214
	8.5-13.0	16.0	11713216

Všechny rozměry v mm.

<b>d1 Ø</b>	Ø $\text{---}$ : 4.1 [4.3 max]
<b>d2 Ø</b>	: 8.0 [+/-0.29]
<b>k</b>	: ≤1.7
<b>P</b>	: ≥27
<b>d3</b>	: 2.18
	⊕ : 1600 N
	⊖ : 1150 N

Všechny rozměry v mm.

<b>d1 Ø</b>	Ø $\text{---}$ : 4.9 [5.2 max]
<b>d2 Ø</b>	: 9.5 [+/-0.29]
<b>k</b>	: ≤2.0
<b>P</b>	: ≥27
<b>d3</b>	: 2.78
	⊕ : 2350 N
	⊖ : 1500 N

	L [+1/-0.2]		Objednáací číslo
	0.5- 2.5	6.0	11714006
	0.5- 4.5	8.0	11714008
	1.0- 6.0	9.5	11714009
	1.5- 6.5	10.0	11714010
	3.5- 8.5	12.0	11714012
	4.0- 9.5	12.7	11714013
	5.5-10.5	14.0	11714014
	7.5-12.5	16.0	11714016
	8.5-13.5	17.0	11714017
	9.5-14.5	18.0	11714018
	11.5-16.5	20.0	11714020

	L [+1/-0.2]		Objednáací číslo
	0.5- 5.0	10.0	11714810
	0.5- 5.5	10.3	11714811
	2.0- 7.0	12.0	11714812
	4.0- 9.0	14.0	11714814
	5.0-10.5	15.1	11714815
	6.0-11.0	16.0	11714816
	7.0-12.0	17.0	11714817
	8.0-13.0	18.0	11714818
	10.0-15.0	20.0	11714820
	12.0-17.0	22.0	11714822
	14.0-19.0	24.0	11714824
	14.5-19.5	24.8	11714825
	17.0-23.0	27.0	11714827
	20.0-25.0	30.0	11714830

# Série 1181

**HLINÍK**  
AlMg 2,5

**OCEL**  
POZINKOVÁNO

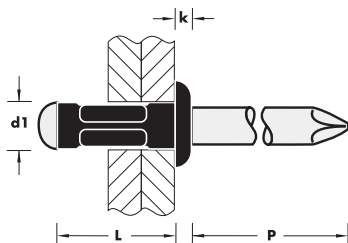

## ČERNÝ LAK RAL 9005

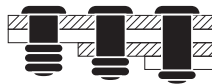

Všechny rozměry v mm.

<b>d1 Ø</b>	Ø $\text{---}$ : 3.1 [3.3 max]
<b>d2 Ø</b>	: 6.0 [+/-0.24]
<b>k</b>	: ≤1.4
<b>P</b>	: ≥27
<b>d3</b>	: ≈1.7
	⊕ : 654 N
	⊖ : 522 N

Všechny rozměry v mm.

<b>d1 Ø</b>	Ø $\text{---}$ : 3.3 [3.5 max]
<b>d2 Ø</b>	: 6.0 [+/-0.24]
<b>k</b>	: ≤1.4 [+/-0.75]
<b>P</b>	: ≥27
<b>d3</b>	: ≈1.78
	⊕ : 980 N
	⊖ : 680 N

	L [+1/-0.2]		Objednáací číslo
	1.0- 4.0	6.0	11813006
	1.0- 5.5	8.0	11813008
	2.5- 7.0	10.0	11813010
	4.5- 9.0	12.0	11813012

	L [+1/-0.2]		Objednáací číslo
	0.5- 3.0	6.0	11813206
	0.5- 5.0	8.0	11813208
	2.0- 6.5	9.5	11813209
	2.5- 7.0	10.0	11813210
	3.5- 8.0	11.1	11813211
	4.5- 9.0	12.0	11813212
	5.5- 9.5	12.7	11813213
	6.5-11.0	14.0	11813214
	8.5-13.0	16.0	11813216

Všechny rozměry v mm.

<b>d1 Ø</b>	Ø $\text{---}$ : 4.1 [4.3 max]
<b>d2 Ø</b>	: 8.0 [+/-0.29]
<b>k</b>	: ≤1.7 [+/-0.1]
<b>P</b>	: ≥27
<b>d3</b>	: ≈2.18
	⊕ : 1600 N
	⊖ : 1150 N

Všechny rozměry v mm.

<b>d1 Ø</b>	Ø $\text{---}$ : 4.9 [5.2 max]
<b>d2 Ø</b>	: 9.5-9.8 [+/-0.29]
<b>k</b>	: ≤2.0 [+/-0.1]
<b>P</b>	: ≥27
<b>d3</b>	: ≈2.78
	⊕ : 2350 N
	⊖ : 1500 N

	L [+1/-0.2]		Objednáací číslo
	0.5- 2.5	6.0	11814006
	0.5- 4.5	8.0	11814008
	1.0- 6.0	9.5	11814009
	1.5- 6.5	10.0	11814010
	3.5- 8.5	12.0	11814012
	4.0- 9.5	12.7	11814013
	5.5-10.5	14.0	11814014
	7.5-12.5	16.0	11814016
	8.5-13.5	17.0	11814017
	9.5-14.5	18.0	11814018
	11.5-16.5	20.0	11814020

	L [+1/-0.2]		Objednáací číslo
	0.5- 5.0	10.0	11814810
	0.5- 5.5	10.3	11814811
	2.0- 7.0	12.0	11814812
	4.0- 9.0	14.0	11814814
	5.0-10.5	15.1	11814815
	6.0-11.0	16.0	11814816
	7.0-12.0	17.0	11814817
	8.0-13.0	18.0	11814818
	10.0-15.0	20.0	11814820
	12.0-17.0	22.0	11814822
	14.0-19.0	24.0	11814824
	14.5-19.5	24.8	11814825
	17.0-23.0	27.0	11814827
	20.0-25.0	30.0	11814830

ŠIROKOROZSAHOVÉ NÍTY

# Série 1663 + 1441

**HLINÍK**  
AIMg 2,5

**NEREZ**

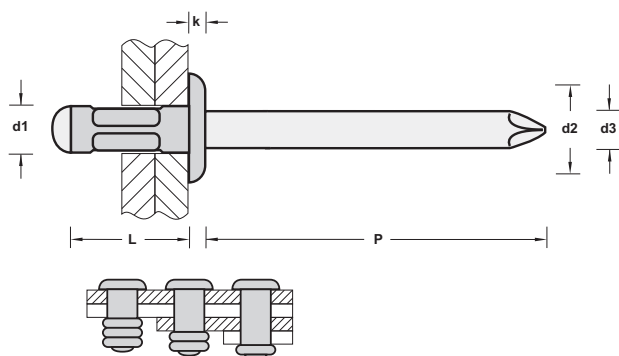

řada 1441 [1.4016]

řada 1663 - d1 - 3, 3,2, 4 mm - mat. [1.4301]

řada 1663 - d1 - 4,8 mm - mat. [1.4567]

Všechny rozměry v mm.

d1 Ø	Ø : 3.1 - 3.3	L	Objednáací číslo
<b>3.0</b>	d2 Ø : 6.7	0.8- 4.3	9.1
	k : ≤1.3		
	P : ≥27		
	d3 : ≈1.7		
	⊕ : 900 N		
⊖ : 700 N			

Všechny rozměry v mm.

d1 Ø	Ø : 3.3 - 3.4	L	Objednáací číslo
<b>3.2</b>	d2 Ø : 6.0 - 6.7	0.8- 4.8	7.9
	k : ≤1.4	0.5- 5.0	8.0
	P : ≥27	2.0- 6.5	9.5
	d3 : ≈1.78	3.5- 8.0	11.1
	⊕ : 980 N	4.0- 7.9	12.0
⊖ : 680 N	5.5- 9.5	16.0	

Všechny rozměry v mm.

d1 Ø	Ø : 4.1 - 4.2	L	Objednáací číslo
<b>4.0</b>	d2 Ø : 8.0 - 8.2	0.5- 3.2	9.3
	k : ≤1.7	0.8- 4.7	10.7
	P : ≥27	1.2- 6.3	9.5
	d3 : ≈2.1	1.0- 6.0	9.5
	⊕ : 1600 N	4.0- 9.6	12.7
⊖ : 1000 N	4.0- 9.5	12.7	
		6.4-12.7	16.7
		8.3-13.5	16.9

Všechny rozměry v mm.

d1 Ø	Ø : 4.9 - 5.1	L	Objednáací číslo
<b>4.8</b>	d2 Ø : 9.5 - 10.1	1.6- 6.3	10.3
	k : ≤2.0	0.5- 5.5	10.3
	P : ≥27	4.8-11.1	15.1
	d3 : ≈2.78	5.0-10.5	15.1
	⊕ : 2350 N	6.4-12.7	16.7
⊖ : 1300 N	7.0-12.0	16.9	
		12.7-19.8	24.5
		14.5-19.5	24.9

# Série 1002

**HLINÍK**  
AIMg 2,5

**OCEĽ**  
POZINKOVÁNO

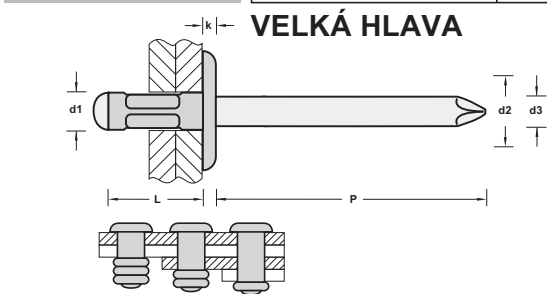

Všechny rozměry v mm.

d1 Ø	Ø : 4.1 [4.3 max]	L	Objednáací číslo
<b>4.0</b>	d2 Ø : 12.0 [+/-0.5]	0.5- 4.5	8.0
	k : ≤2.5	1.5- 6.5	10.0
	P : ≥27	2.5- 7.5	11.1
	d3 : ≈2.18	3.5- 8.5	12.0
	⊕ : 1600 N	4.0- 9.5	12.7
⊖ : 1150 N	5.5-10.5	14.0	
		7.5-12.5	16.0
		8.5-13.5	17.0
		9.5-14.5	18.0
		11.5-16.5	20.0

Všechny rozměry v mm.

d1 Ø	Ø : 3.3 [3.5 max]	L	Objednáací číslo
<b>3.2</b>	d2 Ø : 9.5 [+/-0.5]	0.5- 5.0	8.0
	k : ≤2.0	2.0- 6.0	9.5
	P : ≥27	2.5- 7.0	10.0
	d3 : 1.78	3.5- 8.0	11.1
	⊕ : 980 N	4.5- 9.0	12.0
⊖ : 680 N	6.5-11.0	14.0	
		8.5-13.0	16.0

Všechny rozměry v mm.

d1 Ø	Ø : 4.9 [5.2 max]	L	Objednáací číslo
<b>4.8</b>	d2 Ø : 14.0 [+/-0.24]	0.5- 5.0	10.0
	k : ≤2.5	2.0- 7.0	12.0
	P : ≥27	4.0- 9.0	14.0
	d3 : 2.78	6.0-11.0	16.0
	⊕ : 2350 N	8.0-13.0	18.0
⊖ : 1500 N	10.0-15.0	20.0	

## Série 1003

**HLINÍK**  
AlMg 2,5

**OCEL**  
POZINKOVÁNO

### VELKÁ HLAVA

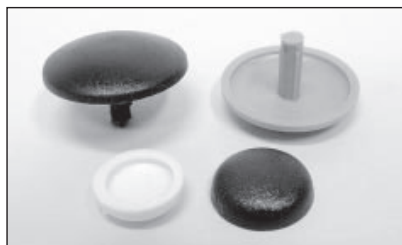
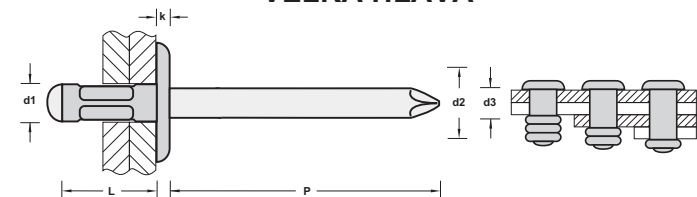

Plastové krytky na zvl. poptávku.

Všechny rozměry v mm.

d1 Ø	Ø $\overline{\text{---}}$ : 4.9 - 5.0
d2 Ø	: 15.6 - 16.0 [+/-0.5]
k	: 2.2-2.5
P	: ≥27
d3	: ≈2.7- 2.8
	: 2100 N
	: 1300 N

**4.8**

+0.05  
-0.15

	L [+1/-0.2]	Objednáací číslo
0.5- 5.0	10.0	10034810
2.0- 7.0	12.0	10034812
4.0- 9.0	14.0	10034814
6.0-11.0	16.0	10034816
8.0-13.0	18.0	10034818
10.0-15.0	20.0	10034820
12.0-17.0	22.0	10034822
14.0-19.0	24.0	10034824
16.0-22.0	27.0	10034827

## Série 1643

**HLINÍK**  
AlMg 2,5

**NEREZ**

### VELKÁ HLAVA A2 [1.4541]

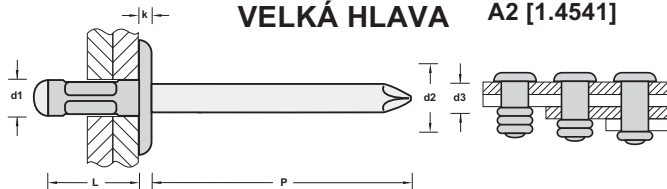

Všechny rozměry v mm.

d1 Ø	Ø $\overline{\text{---}}$ : 4.9 - 5.0
d2 Ø	: 15.6
k	: 1.8
P	: ≥30
d3	: ≈2.8
	: 2335 N
	: 1310-1535 N (dle délky nýtu)

**4.8**

+0.05  
-0.15

	L [+1/-0.2]	Objednáací číslo
1.6- 6.4	10.3	16430613
6.4-12.7	16.9	0621
12.7-19.8	24.8	0631

## Série 1604 + 1004

**HLINÍK**  
AlMg 2,5

**OCEL**  
POZINKOVÁNO

### ZAPUŠTĚNÁ HLAVA

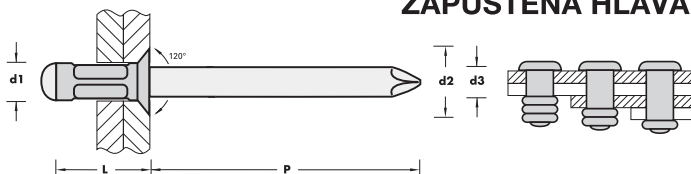

Všechny rozměry v mm.

d1 Ø	Ø $\overline{\text{---}}$ : 4.1-4.2 [4.3 max]
d2 Ø	: 6.3-8.0 [+/-0.24]
P	: ≥27
d3	: ≈2.1
	: 1330 N
	: 1150 N

**4.0**

+0.05  
-0.15

	L [+1/-0.2]	Objednáací číslo
1.5- 4.5	8.0	10044008
1.5- 6.5	10.0	10044010
2.8- 7.9	11.2	16040514
2.5- 7.5	11.3	10044011
3.5- 8.5	12.0	10044012
5.5-10.5	14.0	10044014
3.6- 8.8	15.1	16040515

Všechny rozměry v mm.

d1 Ø	Ø $\overline{\text{---}}$ : 3.3-3.4 [3.5 max]
d2 Ø	: 5.3-6.0 [+/-0.24]
P	: ≥27
d3	: ≈1.8
	: 980 N
	: 680 N

**3.2**

+0.05  
-0.15

	L [+1/-0.2]	Objednáací číslo
1.5- 5.0	8.0	10043208
2.4- 6.3	12.2	16040412
2.5- 6.5	9.7	10043209
2.5- 7.0	10.0	10043210
4.5- 9.0	12.0	10043212
4.0- 7.9	13.4	16040414
5.5- 9.5	14.8	16040416

Všechny rozměry v mm.

d1 Ø	Ø $\overline{\text{---}}$ : 4.9 - 5.0
d2 Ø	: 9.0 - 9.5
P	: ≥27
d3	: ≈2.8
	: 2355 N
	: 1310 N

**4.8**

+0.05  
-0.15

	L	Objednáací číslo
1.5- 5.0	10.0	10044810
2.0- 7.0	12.0	10044812
3.2- 7.9	12.0	16040615
4.0- 9.0	14.0	10044814
6.0-11.0	16.0	10044816
6.3-12.7	16.8	16040621
7.0-12.0	16.9	10044817

# Série 1451



A2 [1.4301]

A2 [1.4301]

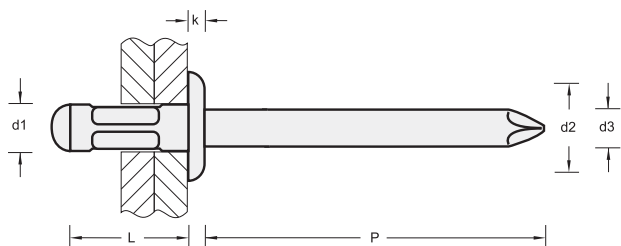

Všechny rozměry v mm.

d1 Ø	Ø  : 3.3	L		Objednáací číslo
		1.5- 4.0	8.0	
<b>3.2</b>	d2 Ø : 7.2 [+/-0.25]			14513208
	k : 1.0 [+/-0.15]			
	P : ≥27			
	d3 : ~2.1			
	: 1780 N			
	: 1570 N			

Všechny rozměry v mm.

d1 Ø	Ø  : 4.1	L		Objednáací číslo
		1.5- 5.0	10.0	
<b>4.0</b>	d2 Ø : 8.1 [+/-0.25]	1.6- 6.4	12.0	14514010
	k : 1.2 [+/-0.15]	6.0- 9.5	15.0	4012
	P : ≥27			4015
	d3 : ~2.6			
	: 3350 N			
	: 3200 N			

Všechny rozměry v mm.

d1 Ø	Ø  : 4.9	L		Objednáací číslo
		1.5- 5.0	10.0	
<b>4.8</b>	d2 Ø : 9.8 [+/-0.25]	3.0- 7.0	12.0	14514810
	k : 1.75 [+/-0.15]	6.5-10.0	15.0	4812
	P : ≥27	9.0-12.5	17.5	4815
	d3 : ~3.2			4817
	: 4300 N			
	: 5000 N			

ŠIROKOROZSAHOVÉ NÍTY